



## Understanding Friction Cracking and its

causes

**Not all cracks are the same.** Many people see a crack and assume rust jacking, but to fully understand your problem and more importantly, find a long-term solution, it's critical to determine what type of crack you have and identify its root cause.

**Examining the type of crack will help you define the issue and find a solution.**

**5 Categories of unacceptable cracks – reference TMC RP 627:**

1. Horizontal sidewall cracks
2. Vertical sidewall cracks that cross the friction
3. Vertical sidewall cracks that spider-web the friction
4. Cracking, chunking resulting in missing material
5. Pitting and crumbling

## Horizontal Edge Cracks

**Appearance** – delamination, appears to be a separation of layers within the friction.

**Most likely causes:**

- Poor friction integrity
- Surface of the friction heats more rapidly than the base, expansion causes friction to delaminate
- Higher quality frictions are more dimensionally stable and have more structural integrity to mitigate this issue
- Low quality frictions with low flexural strength

**Solution** – Make certain your supplier is capable of testing friction and ensuring that it's capable of holding up in the application. In particular, make sure that they are paying close attention to flexural strength.

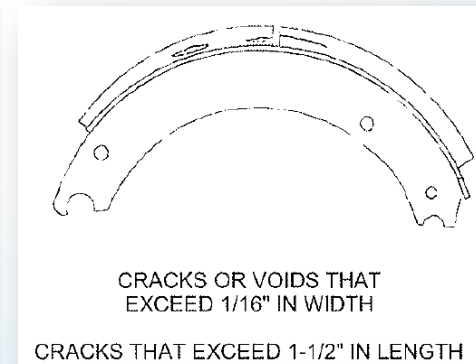

## Vertical Edge Cracks

**Appearance** – Cracks extend vertically up the sidewall of the friction and travel directly across the face of the friction.

**Most likely causes:**

- Un-coined shoe--the friction is being forced to conform and the stress is cracking the friction
- Poor flexural strength of the friction
- Mismatch of geometry between the shoe and friction block, possibly due to issues with the grind of the friction or shape of the shoe

**Solution** – Make certain the remanufacturer you are selecting is coining all shoes and has a full understanding of the dimensions of the brake shoe, most likely learned through OE design and production.

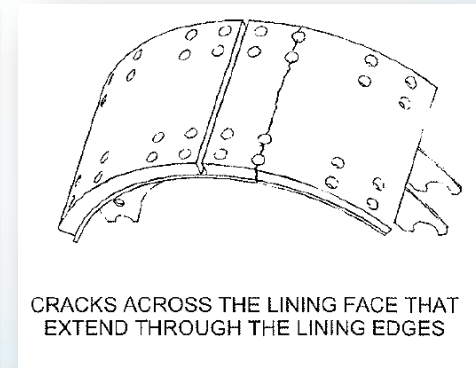

## Spider Web Cracks

**Appearance** – Spider web from central point.

**Most likely causes:**

- An elevated point (Stress Riser) under the friction has created a pressure point
- Poor flexural strength – friction can't hold up to inherent imperfections in the brake
- Corrosion – inadequate coatings to resist environment
- Poor friction fit allows contaminants to enter, leading to corrosion

**Solution** – If the shoe appears heavily corroded, make certain your selected remanufacturer is properly cleaning, blasting and coating shoes to an OE level process.



## Cracking and Chunking resulting in missing friction

**Appearance** – A crack so severe it results in a section of missing friction, often times corner or edge of the friction is broken off.

**Most likely causes:**

- Severe crack – lack of coining
- Missing corner – lack of coining or debris
- Low flexural strength – the friction cannot mechanically hold up to the stress of the application

**Solution** – Select a friction supplier that coins 100% of shoes and offers friction with high flexural strength.

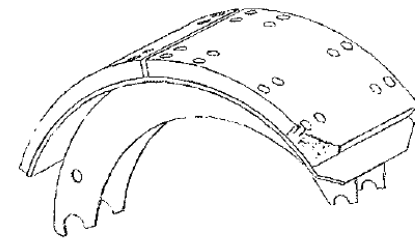

OUT OF SERVICE PORTION OF  
LINING MISSING THAT EXPOSES  
A FASTENING DEVICE

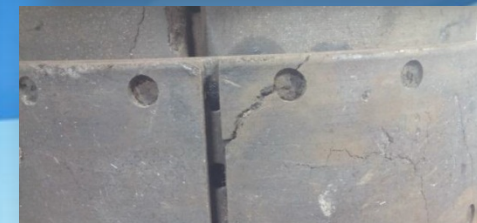

## Pitting and Crumbling resulting in missing friction

**Appearance** – Severe degradation and pitting of the surface. May have a charcoal-like appearance as the friction is burning out and becoming porous.

**Most likely causes:**

- Low quality friction made with low temperature, cheap resins
- Improperly rated friction put into an application beyond its capabilities

**Solution** – Make certain the shoe supplier you select has research and development capability to fully understand the friction they utilize and can properly assign the application ratings.

